

*smart*hone  
Precision Honing Machines



For productive honing  
operations of small  
to medium volumes.

Maximum productivity, minimal changeover times, more flexibility, high precision, simple operation.

### Technology for the ambitions job shop manufacturing

The new generation of smarhnone machines caters in particular to the needs of contract manufacturers in job shop production and prototyping. It meets the highest requirements in regard to flexibility and efficiency. From manual honing in single piece production up to fully automated operations, all suitable operating modes are available. In addition to short set up and machining times, importance was put on an user-friendliness.



Efficient job shop manufacturing

### Highest efficiency in a compact design

All necessary functions, such as the coolant conditioning and superfine filtration, are integrated into a compact floor space of only 1.6 m<sup>2</sup>. The costopti-mized horizontal honing system is designed for the production of most diverse batches and product ranges. Precision work pieces with diameters of 0.8-45 mm and honing lengths of up to 200 mm can be produced very efficiently within short cycle times. Stroke speeds of up to 60 m/min and accelerations of up to 4g are achieved.



Engaged tool

You are looking for a compact, user-friendly honing machine



which is productive, works flexible and can be upgraded modularly?

Specifications		Honing machine
Stroke length	mm	200
Diameter, nominal	mm	0.8 - 45
Spindle drive		servo motor
Speed, max.	1/min	4500
Torque	Nm	31
Stroke drive		linear motor
Max. stroke speed	m/min	60
Stroke acceleration, max	m/s <sup>2</sup>	40
Space requirement (W x D x H)	mm	880 x 2000 x 1600
Net weight	kg	2500
Noise emission	db(A)	< 72
Honing control		Gehring GCU 2.3

Subject to technical changes and variations in design and configuration.

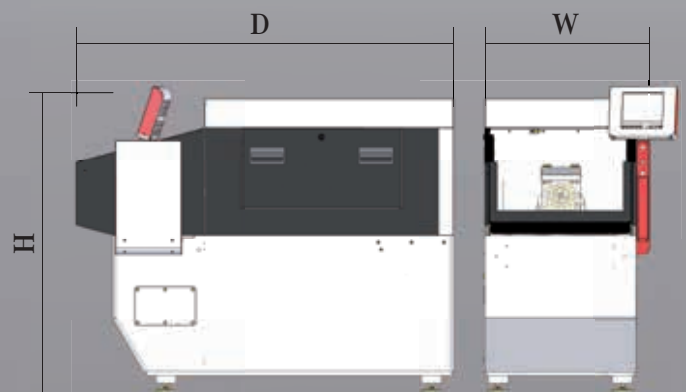

## Machine operation made easy

The set up or retooling of the machine is possible in the shortest time frame due to a configured interface. This also applies to changing and controlling of various types of fixtures, tools and machine functions. The intuitive operator interface minimizes the preparation times and training processes for additional personnel. On the special developed overview screen all the necessary information is displayed for the operator and all required machine functions can be executed.



*Intuitive Gehrung operator panel*

## Automation for simple work piece handling

Another innovation in this segment is the simple integration of an automation unit. The automation cell with robot manages up to 4 secondary processes in addition to the work piece handling. Via plug & play interface, overall communication is ensured including direct feedback of the gauging results to the controller of the honing machine. If need be, a second honing machine can be integrated for double production output or a fully automated 2-stage operation with rough and finish honing.



*Flexible automation cell*

## No Compromises: smarhtone tooling system!

Ensuring the precision without the extensive alignments we offer you an optimized tooling system. Score economically with the especially for the smarhtone designed system. Precision and longevity are the hallmark of our tooling systems. They guarantee highest productivity, optimized surfaces and best possible bore geometries compared to minimal investment costs. Using a multi-stone system, high life times are achieved. With our assembly tooling kit you are able to cover the common honing tasks in diameters of 3-15 mm.

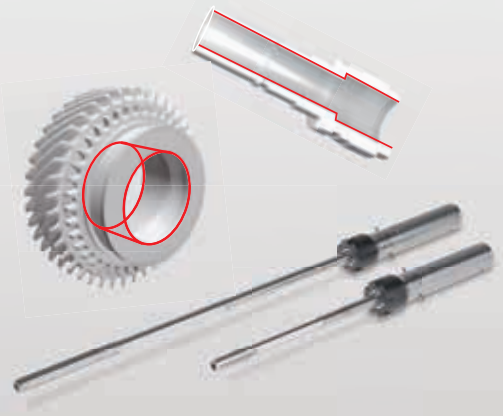

*Tooling system for precision work pieces*

Specifications		Automated
Robot system		Mitsubishi Type RV, 6-Axle
Work piece weight, max.	kg	12
Number of grippers, max.		4
Range, max.	mm	1200
Workpiece carrier system		Pallets with load / unload
Number of secondary processes, max.		4
Secondary processes - gauging		Pre-control / post-gauging
Secondary processes - deburring		System with autom. brush change
Secondary processes - other		Pre-/ postprocesses of workpieces
Space requirement (W x D x H)	mm	850 x 2000 x 2500
Net weight	kg	3200
Noise emission	db(A)	< 72

*Subject to technical changes and variations in design and configuration.*

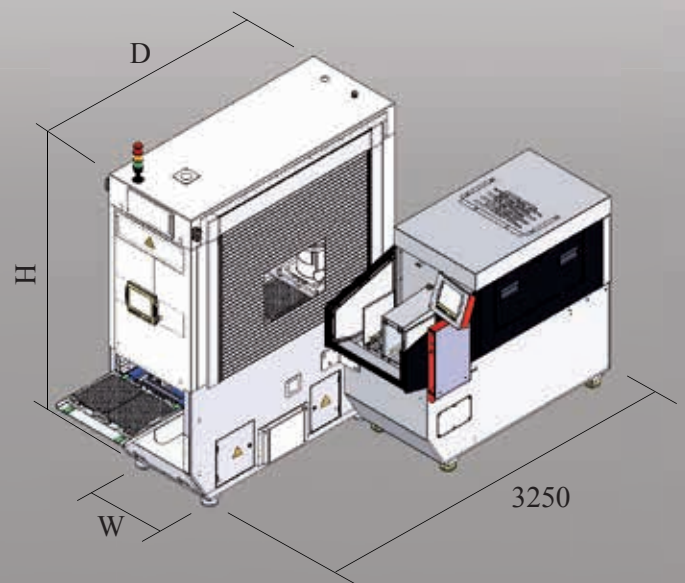

## Features

- Developed for contract and job shop honing production
- Manual single piece and fully automated operations possible
- Honing diameters up to 45 mm
- Honing lengths up to 200 mm
- Electro mechanical expansion with force sensor
- Stroke speeds up to 60 m/min
- Accelerations up to 4g
- Integrated coolant conditioning and superfine filtration

### Optional equipment

- 2-position sliding table for loading/unloading during the semi-automatic operation
- Automation cell with up to 4 secondary processes
- Plug & play interface for flexible integration of peripheral equipment
- Additional honing machine for rough and finish honing or double production output

### Interested?

Contact us today and discuss your individual production needs and attractive financing offers with our smarhtone team.

You can also schedule a personal visit and demonstration in our show room. There, you can see for yourself the advantages and qualities of the smarhtone.



Trust the technology leader with many years' experience and global presence!

Innovative solutions combined with economical thinking is our trademark.

